

Safe Use Matters

Before using the device, please read the instruction manual carefully and follow the warnings about operation and use. The instruction manual should be kept for future reference.

- ◆ This device can only use the type of power supply indicated in the manual.
- ◆ Pay attention to avoid the power cord being squeezed by heavy objects, especially pay attention to the plug of the power cord, the outlet of the device and the convenient socket, and avoid pulling or pumping the power cord by all means.
- ◆ Can not be used near the water source, such as: bathtub, sink, kitchen sink, wash basin, wet basement, swimming pool, etc.
- ◆ The device must be kept away from heat source.Examples: radiators, heating resistors, stoves and other heating devices (including amplifiers).
- ◆ Care must be taken to prevent objects or water from falling into the inner core.If dropped into metal or other conductive material, there is a risk of electric short circuit inside the device.
- ◆ Because the machine memory is high voltage, non-electronic professional technical personnel, do not disassemble the chassis, if the internal electronic parts are not normal contact, serious electric shock accident may occur.The company is not responsible for this incident.
- ◆ Do not use volatile solutions.Such as: alcohol, paint thinner, gasoline, volatile oil and other wipe the shell, the use of clean dry cloth.
- ◆ In case of abnormal odor or smoke, cut off the power supply and pull out the plug immediately. Contact the supplier or the nearest repair department for repair service.
- ◆ A . For safety, please disconnect the power switch and unplug the power plug.In case of fire.
B . To prevent water, metal, flammable products or other foreign matter from falling into the machine, so as to avoid electric shock and fire accident.In case of such accident, please cut off the power supply immediately and stop using it.And with the company's service center or the purchase shop contact, seeking maintenance services.
- ◆ Do not press the power plug under the machine or between other items;Do not set the power supply in the place with frequent traffic, so as not to cause electric shock or fire accident due to plug damage.



warning :

Do not press the power plug under the machine or between other items;Do not set the power supply in the place with frequent traffic, so as not to cause electric shock or fire accident due to plug damage.

Customers need to know

Dear customers,

Thank you for choosing this product! In order to ensure the safety of you and the machine, as well as to enable you to fully enjoy the best product experience, be sure to read this manual carefully before connection or operation, and please keep this manual for future reference after reading.

Open-box inspection:

After unpacking, please first confirm whether there is any damage caused by transportation, and connect the wire according to the requirements of this manual and test each function. If there is any problem, please inform the sales department immediately.



Pay attention to :

- ◆ When purchasing the machine, please check whether the bar code on the back plate of the case is complete, and whether the random accessories are complete.
- ◆ Non-designated maintenance department opened the machine will not be within the scope of the three packages.
- ◆ It is recommended that you keep the removed packaging materials and accessories for future handling or maintenance.

directory

Quick to use.....	4
Function is introduced.....	6
Input channel.....	11
The effect of channel.....	12
The auxiliary channel.....	13
Digital channel.....	14
System Settings.....	15
Mp3 page.....	
Load/save mode.....	16
Copy the page.....	
DCA mute marshalling.....	17

Quick to use

This product is a novel and unique multi-function digital mixer, with small size, light weight, full function, intuitive and simple operation, quick response and many other advantages.

Application scenarios: performance, conference, rental, school, church, cultural hall, wedding, concert, family, band and other occasions.

01. When the mixer is turned off, select one MIC/ LINE input channel, plug in the microphone or CD player and other external audio sources to access the mixer, and make sure that the access channel is in mute state or push the physical push to the lowest position before access.

02. Use the audio casset line to connect to the L/R main output interface at the back of the mixer, and the other end to connect to the power amplifier and the speaker.

03. The mixer is connected to the power supply, turn on the machine, after waiting for the mixer to start completely, the power amplifier is switched on again.

04. After starting the mixer, push the physical pusher that plugs into the MIC/Line input channel into the appropriate position.

05. Then also push the physical pushers of the main output to the appropriate position.

06. Adjust the input gain of the input channel to make the input signal achieve the appropriate dynamic.

07. If you are connected to a capacitive microphone or other device that requires power, turn on the Phantom Power.

08. According to the demand of the signal source, the equalizer is used to enhance or weaken the corresponding frequency band, and the compressor and threshold are used to control the dynamic range.

09. The input signal is sent to each effector, the output bus, and the main output.

10. Change the main push until the sound system produces the right amount of sound.

Features - Front panel

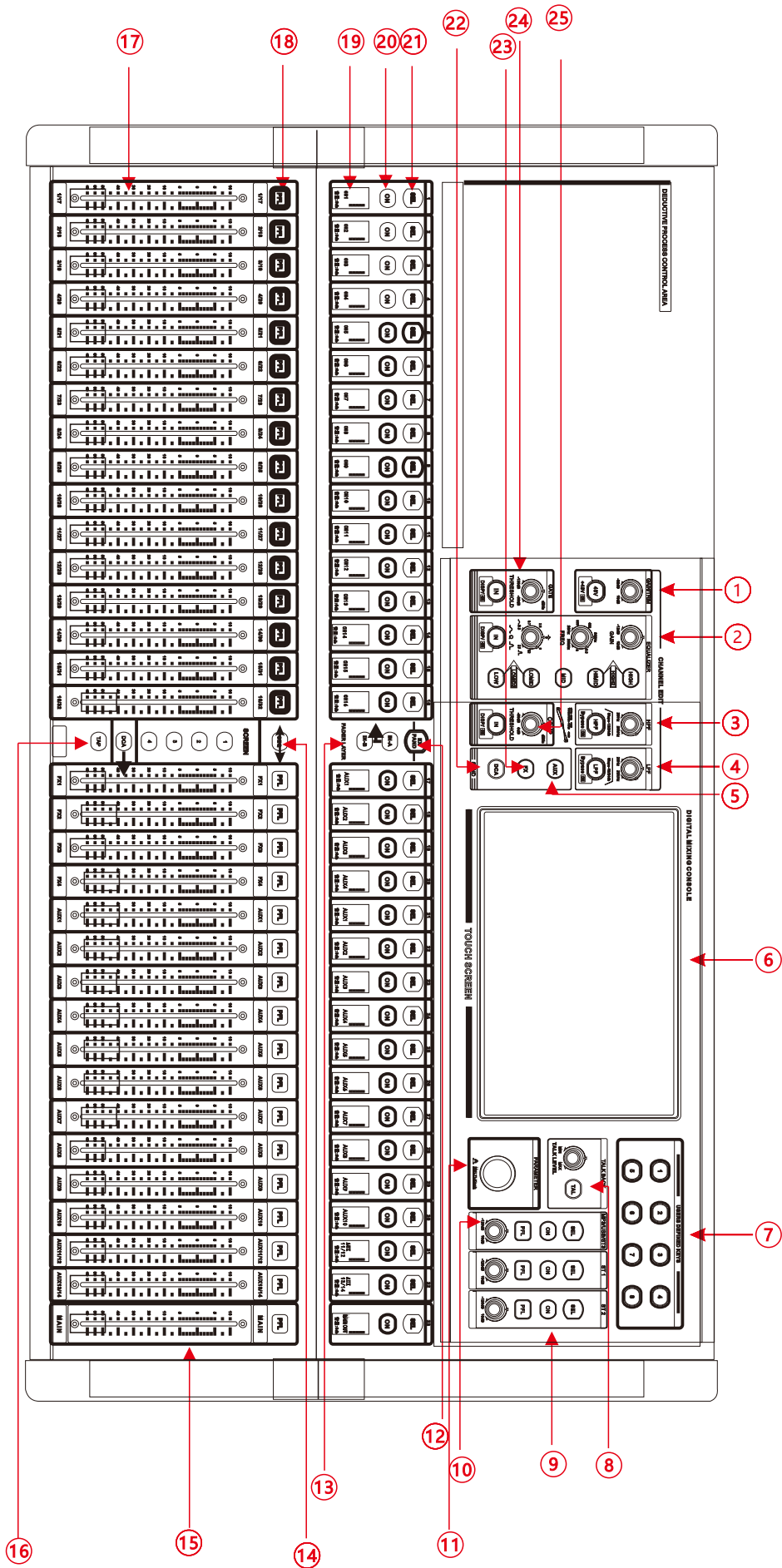

Features - Front panel

1, Input channel gain /+ 48V switch

1). Gain control

Adjust this knob to increase or decrease the input signal level.

2).48V phantom power button

Long press the button for 3 seconds to turn on the 48V power supply of the current channel and light it, indicating that the MIC jack has 48V voltage.

Note: Do not turn on the phantom power until you have connected the microphone.

2. EQ/ Equalizer

1). Equalizer parameter knob

Up to down means: gain, frequency and Q value.

2). Parameter equalizer button

The shortcut keys of the parameter equalizer are: treble, medium treble, medium, bass and bass (from top to bottom). After lighting the corresponding keys, match the three parameters on the left

Adjust the knob to adjust the EQ parameters,

Note: The EQ adjustment is only effective when the EQ switch (IN key) is on.

3/4, channel HPF/LPF(high and low pass filter)

1).(HPF) high pass knob/high pass switch

Adjust this knob to reduce the low frequency signal, HPF button is high frequency on and off.

2).(LPF) Low Pass Knob/Low Pass Switch

Adjust this knob to reduce the high frequency signal, LPF button is low pass frequency on and off.

The high-low pass filter can be treated as a frequency divider

5. AUX channel signal delivery button

In the push layer A or InB

The button light of corresponding auxiliary output flashes to indicate that the current push is in the state that the channel sends to the corresponding auxiliary output

The send size is controlled by the corresponding pusher or the on-screen send bar.

6, 10.1 inch high-definition capacitive touch screen

7. Eight user-defined buttons

The factory default function is the scene mode call key, which can be changed by user-defined key function

8. Talk Back

It can be used as an intercom function by setting any input or output channel

9, stereo input 1/2(ST1/ST2) control area

SEL selection key to access channel page, mute switch, monitor switch, and volume knob (equivalent to push rod)

10, digital input channel (MP3/ sound card control /AES input)

1).SEL channel selection key

The button lights up to indicate that a channel has been selected and that channel parameters can be edited.

2).ON mute switch

Digital channel mute switch, off when the channel is mute state, you will not hear the signal of the channel

3).PFL monitor switch

When this button is pressed, the signal will be output from the listener and the headset.

4). Volume knob

The knob currently controls the volume of the digital channel.

11. Multi-function knob

This knob cooperates with the touch screen for parameter adjustment

12. Connect remote network EXPAND button Expand

When the host local input and output is not enough to use, with a dedicated stage interface box, through the network cable connection, long

Press this button to connect. When the connection is completed, the button begins to blink, indicating that the connection is successful. At this time, you can connect in

The interface box is operated on the host machine to realize the remote audio expansion and control of input and output

Features - Front panel

13/14. Enter the page-turning button /GEQ mode button

Input/output channel push page turn button

In -A When this button is on, the push control corresponds to the input channel level of the first layer.

In -B When this button is on, the push control corresponds to the level of the second input channel.

GEQ- This button is effective when selecting the output channel. When the button is on, the push controls the gain of the output equalizer.

15. Right side push

For four-way effect channel and auxiliary output main output level adjustment (electric push)

16. Quickly invoke the first four scene modes /DCA marshalling Settings /TAP effect beat buttons

1) .Click the corresponding button to quickly invoke the scene parameters, and long press to quickly save the parameters to the corresponding scene

2) .Click to edit DCA marshalling. Set DCA marshalling by marshalling corresponding input/output channels

3) .Short Delay Medium Delay Long Delay Is the beat effect, click Tap to change the echo delay time

17. Input channel pushers

Used to control the level of the current input channel (electric push)

18. PFL monitor switch

When this button is pressed, the signal will be output from the listener and the headset

19. Channel guide small display screen

This small screen will video display the current channel push volume, name, level signal and other information

20. ON The mute switch

Channel mute switch, off the channel will be in mute state, you will not hear the signal of the channel

21. SEL Channel selection key

The button lights up to indicate that a channel has been selected and that channel parameters can be edited

22. DCA Send button

Click the button to set the DCA marshalling group into which the currently selected channel should be marshalled

23. FXChannel signal delivery button

Pressing the button to start flashing indicates that the pusher is in the state of the signal level sent to the FX effect channel by the corresponding channel

The send size is controlled by the corresponding pusher or the on-screen send bar

24. GATE/Noise of the door

This knob can adjust the threshold size of the noise door, and the IN button controls the opening and closing of the noise door

25. COMP/Pressure limiting device

This knob can adjust the threshold size of the limiter. The IN button controls the opening and closing of the limiter

Features - latest version

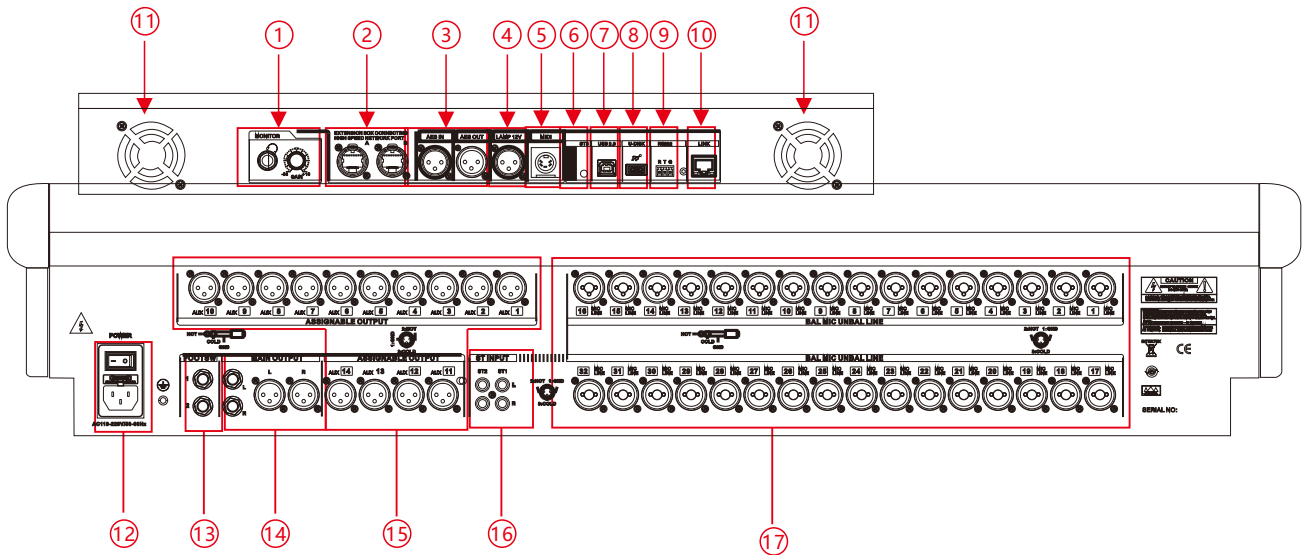

1. Monitor headphone jack/with monitor knob
Insert the headset into this jack. It is recommended that the impedance of the headset be greater than 150 ohm. Monitoring level knob This knob is used to control the monitoring signal level.
2. Network extension interface
Can be connected to the special interface box for input and output expansion, through the network transmission control
3. AES digital signal input/output interface
4. LAMP-12V Output interface, can be connected to the same voltage of the gooseneck lamp.
5. MIDI Signal input interface
6. 3.5 Stereo headphone input interface
7. Square USB interface
Connect the computer software debugging, and connect to the computer as a sound card audio input interface.
8. USB interface
MP3 audio input playback recording and system upgrade interface.
9. Central control RS232 interface
External connection 232 control equipment control connection.
10. Network interface
External router wireless remote control or network cable directly connected to the computer connection control.
11. Two cooling fans
12. Power input port and switch
110V-220V power interface.
13. Effect switch jack
This is the connection of the foot switch. If necessary, you can connect it here.
14. Main output LR output interface (balanced and non-balanced)
L/R outputs signals to power amplifiers or other amplifiers.
15. AUX1-14 auxiliary output interface
AUX1-14 auxiliary output signals to power amplifiers or other amplifiers.
16. Two ST stereo input
Stereo line input interface.
17. MIC/ LINE microphone input interface
All are balanced input ports, 32 XLR jacks, can be connected to XLR line or use 1/4 "TRS line to connect the audio signal source.

Function Description - Product size - 32Ch

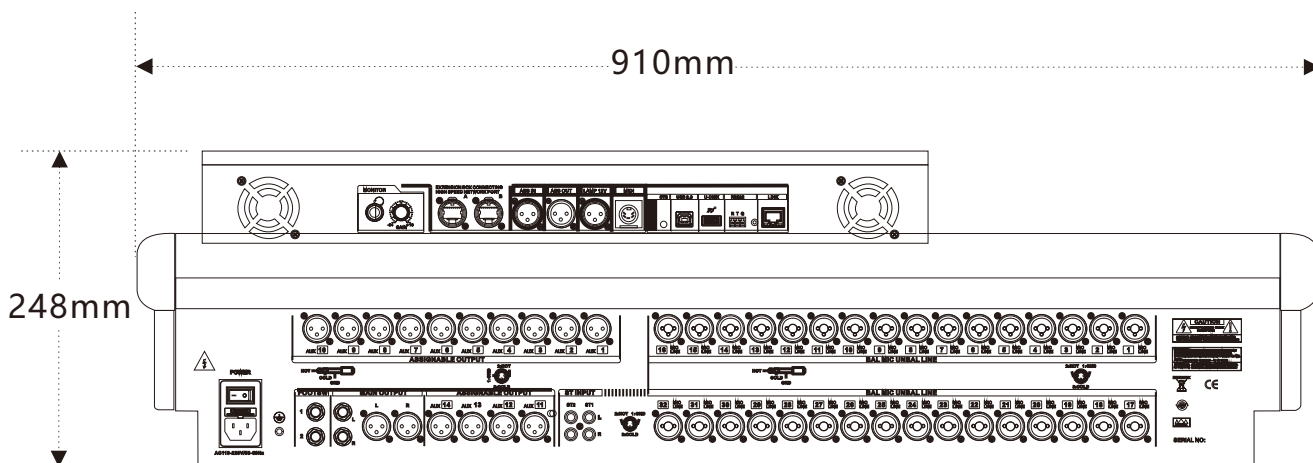
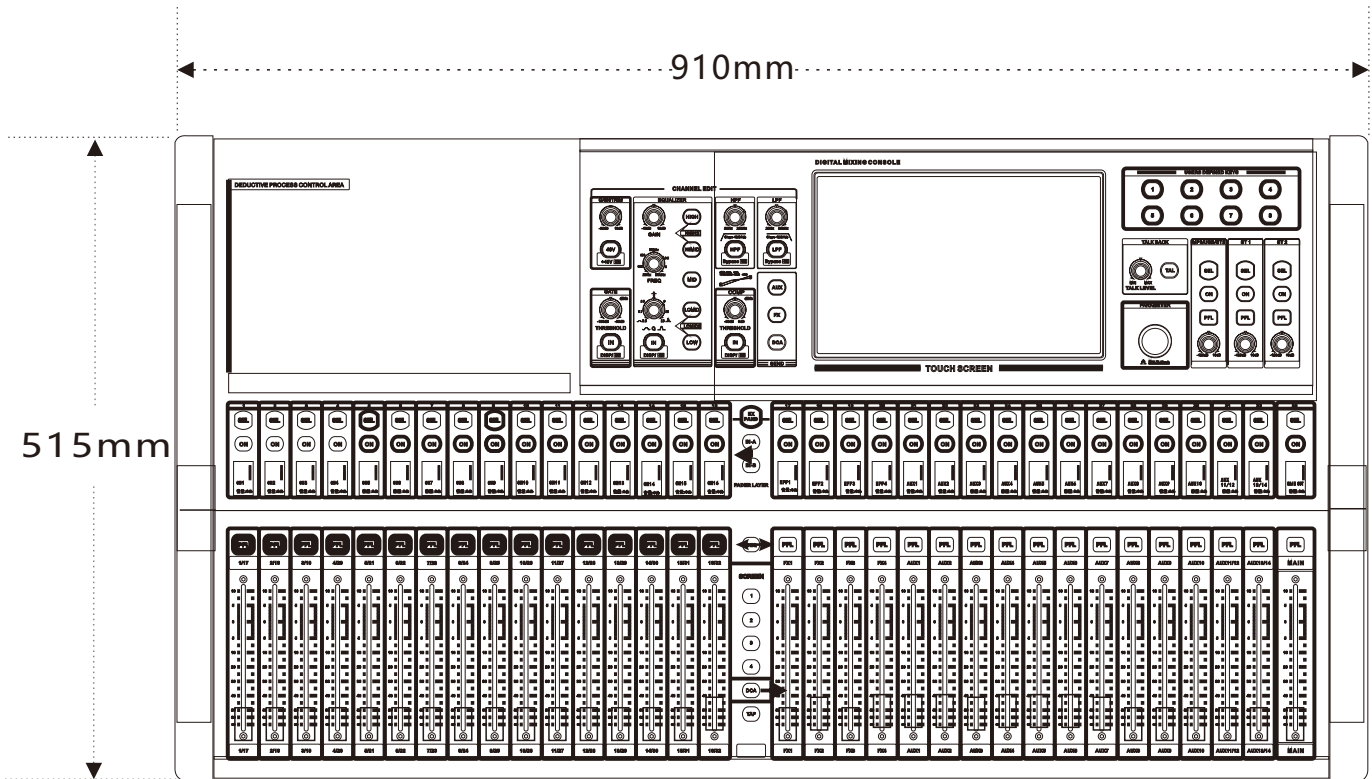

Length, width and height: 910*515*248MM (length includes 6.35 input seat, width includes side plate, height includes machine leg;Knobs not included)

Net weight: 18.25kg Gross weight: 19.05kg Packing size: 1040*630*360MM

Input channel



Channel main plane

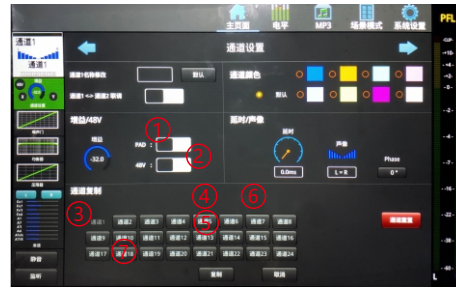

Enter the channel edit page

Boot the default to enter the main page.

Click the icon on the home page in the menu bar and swipe left and right to switch channel selection options and select different channels to enter
 Click the level display icon to enter the level interface and display the real-time level signals of different channels
 Click the MP3 icon to enter the MP3 operation interface, by reading the U disk audio information for MP3 playback, recording and other operations
 Click the scene mode icon to enter, you can save or load the scene mode, as well as input and output port.
 System Settings icon click for network, language selection, custom layer and other function settings.

Click to enter the corresponding input channel editing page.
 The input channel edit page includes channel name and color modification, channel link co-modulation settings, gain status display, PAD volume attenuation switch, channel 48V phantom power switch, channel delay, audio and image adjustment, input reverse, channel parameter copy operation, mute and listening switches.

1. Channel name: touch the name to modify the current channel name and background color, and click Default Restore.
2. Channel Link Modulation: Click to set the function of adjacent channels and switch to open and close the modulation.
3. Gain display: Gain/GAIN knob on the panel to control the size.
4. PAD switch: attenuation input signal switch.
5. 48V phantom power switch: the current channel 48V phantom power switch state.
6. Delay/sound and image adjustment: this area can adjust the input delay, signal balance, input signal reverse.
7. Channel parameter copy: click to copy the current channel parameter settings to other input channels.

Channel noise door page: touch the noise door area on the left side of the screen to enter. This page can adjust the threshold value, start time, hold time and release time of the channel noise door, as well as switch control for opening and closing

Channel equalizer page: touch the equalizer area on the left side of the screen to enter. This page can adjust the gain, frequency, bandwidth, high and low frequency, high-pass type and low-pass type of five-segment parameter equalizer. Switch controls the opening and closing of the equalizer

Channel pressure limiter page: Enter the pressure limiter area on the left side of the screen. This page can adjust the threshold, compression ratio, start time, release time and output gain of channel pressure limiter. It is divided into three types: hard pressure, medium pressure and soft pressure, and switch controls on and off

Send page: send area into the touch screen on the left channel, this page can adjust the current input channel to the main output LR, various auxiliary channel and the effect of signal values, click on the auxiliary channel below the article send button can adjust the clipper before/after the clipper mode, click on the effect of channel to send the buttons below to quickly access to the currently selected effect. (When entering this interface, the AUX or FX button on the left side of the screen will start flashing. This is the rapid adjustment mode. You can adjust the sending value by adjusting the corresponding input channel push, and click the flashing button again to exit the rapid adjustment mode.)

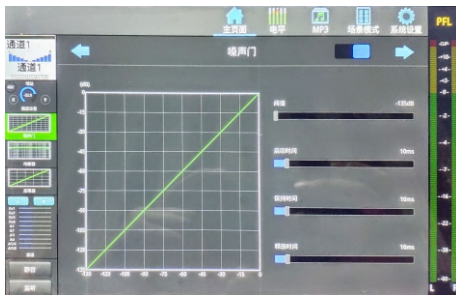

Channel noise gate page

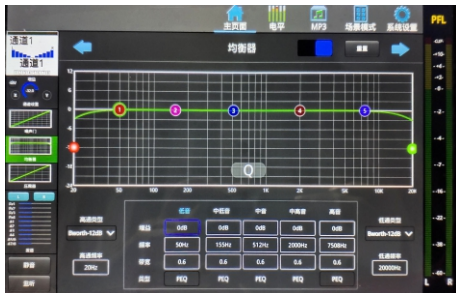

Channel equalizer page

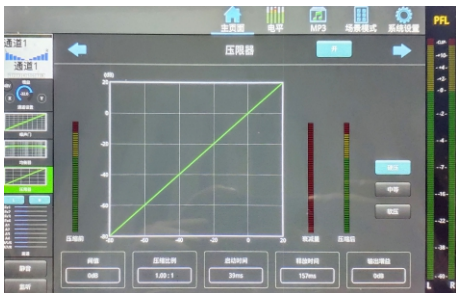

Channel Limiter page

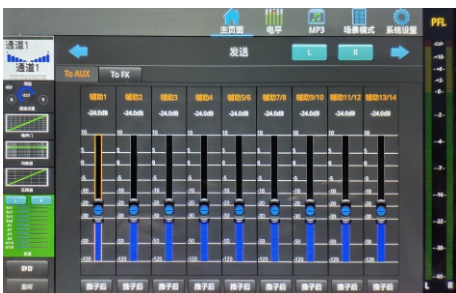

Channel sending page

Click the home page icon at the top of the screen to return to the home page interface.

The effect of channel



Main page of effect



Effect volume source

Displays the status of the input channel sent to the current effect

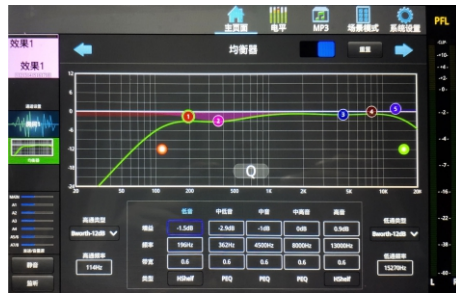

Effect equalizer



Effects User effects parameters



The effect is sent to the output channel page

How to enter the effector page.

Find the word "Write (FX) effect channel" on the screen print on the right output push layer board, and click the SEL button to turn on FX effect to enter the main page.

Effects channel page has volume source, equalizer, user effects, send.

1. Touch the corresponding function area to enter the function page.
2. Click to select the parameters to be adjusted, and then adjust them through the multi-function knob or touch screen.
3. Click the home page icon at the top of the screen to return to the channel home page.

To enable the effect, click the volume source in the sending area on the left side of the touch screen of the effect channel interface and adjust the signal size of the corresponding input channel to about 0dB. Then click "Send" and adjust the signal size of the corresponding output channel to about 0dB. Push the push of the effect channel to adjust the effect volume

The effect mode interface can be used to store and call the effect mode

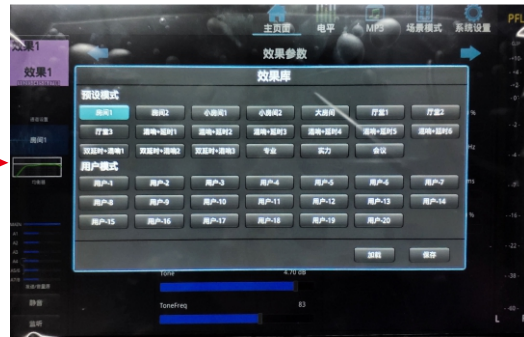

Type of effect parameter

Effect of name	Effect type/value					
Foot Switch	Effect 1		Effect 2		Effect of 1 + 2	
Wah-Wah	Filter	0Hz-8000Hz	Auto	0%-100%	Resonance	0%-100%
	Filter Type	BPF				
		LPF				
Distortion	On/off					
Pitch-shift	1 / 2 Tone	-12—+12	Fine Tune	0127	Filter	0Hz-8000Hz
	Resonance	0%-100%	Dry/Wet-Mix	0%-100%		
Reverb/Delay	Type:	Spring	Hall	Cathedral	Slap-Back	Short-Delay
		Medium-Delay	Long-Delay	Delay Reverb 1	Delay Reverb 1	
	LevelRev	0%-100%	PreHP	0Hz-1200Hz	PreDelay	0ms—127ms
	TimeRev	0%-200%	HDamp	0%-100%	Tone	-22.0dB+22.0dB
	ToneFreq	0—127				
Mod-FX	Type:	Vibrato	StepPhaser	Tremolo	SineChorus	Phaser
		Panning	Flanger	Chorus		
	Level	0%-100%	DelTime	0ms—127ms	Feedback	0%-100%
	PreHP	0Hz-1200Hz	HDamp	0%-100%	Rate	0.02Hz-5.80Hz
	Depth	0%-100%	Tremshape	0%-100%		

Click the corresponding mode button in the user area, select "Load" below to call, and select "Save" to save the effect parameters into this mode.

Auxiliary output channel

How to enter the secondary output page.

Find the words with AUX assistance on the screen printing of the right output push layer board, click the SEL button to open AUX assistance to enter the main page, or slide left and right on the main page at the top of the screen to find the auxiliary output channel and click in

The auxiliary output edit page displays channel name/color change, output delay, output reverse, output channel parameter copy, equalizer, voltage limit, volume source signal adjustment, mute and monitor keys

1. Touch the corresponding function area to enter the function page.
2. Click to select the parameters to be adjusted, and then use the multi-function knob to adjust.
3. Click the home page icon at the top of the screen to return to the channel home page.

Channel equalizer page: touch the equalizer area on the left side of the screen to enter. This page can adjust the gain, frequency, bandwidth, high and low cut frequency, high-pass type and low-pass type of the output channel 15 segment parameter equalizer. Switch controls the opening and closing of the equalizer.

Aux output volume source choice: touch screen on the left into the channel signal bar area, the page you can adjust the current output channel signal source channel volume value, the corresponding channel, click on the screen with multi-function knob or touch screen to adjust, after the adjustment to promote corresponding input/output pusher to auxiliary input channel can be realized in the volume of the output channel.

Channel pressure limiter page: Enter the pressure limiter area on the left side of the screen. This page can adjust the threshold, compression ratio, start time, release time and output gain of channel pressure limiter. It is divided into three types: hard pressure, medium pressure and soft pressure, and switch controls on and off



Auxiliary output main page



Auxiliary output volume source

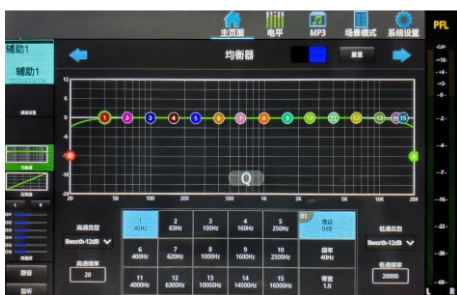

Secondary output equalizer page

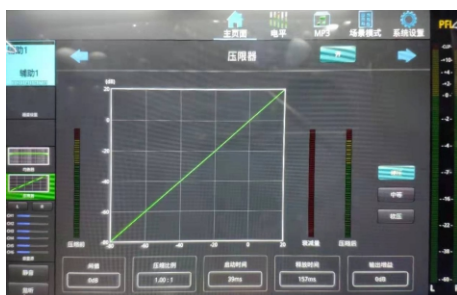

Auxiliary output voltage limiter page

Digital channel



Digital channel home page

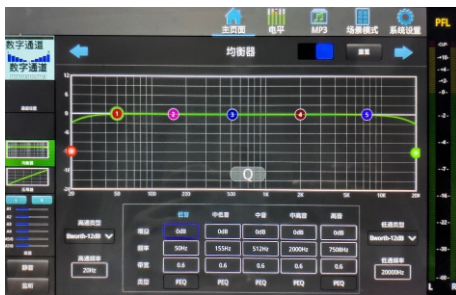

The equalizer page

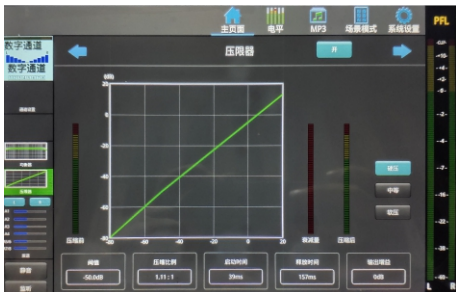

Pressure limiter page



Digital channel signals are routed to the output page

How to access the digital channel page.

Under the MP3/USB screen printing on the right side of the screen, click the SEL button to open the digital channel to enter the main screen. Or through the top of the screen home page left and right slide to find the digital channel to click into

1. Touch the corresponding function area to enter the function page.
2. Click to select the parameters to be adjusted, and then adjust them through the multi-function knob or touch screen.
3. Click the home page icon at the top of the screen to return to the channel home page.

The digital channel edit page displays channel name/color change, audio-visual balance adjustment, input reverse, channel parameter reset, equalizer, voltage limiter, volume signal transmission adjustment, mute and listening buttons.

MP3 and sound card playback control is through the digital channel to adjust the volume knob through the digital channel to adjust the volume.

Channel equalizer page: touch the equalizer area on the left side of the screen to enter. This page can adjust the gain, frequency, bandwidth, high and low frequency, high-pass type and low-pass type of five-segment parameter equalizer. Switch controls the opening and closing of the equalizer.

Channel sending page: touch the channel sending area on the left side of the screen to enter. This page can adjust the digital channel to output LR to the main channel and the signal sending value of each auxiliary channel. Click the button at the bottom of the auxiliary channel sending bar to adjust the Push Before/Push After mode.

Digital channel limiter page: Enter the limiter area on the left side of the screen. This page can adjust the threshold value, compression ratio, start time, release time and output gain of channel limiter. It can be divided into three types: hard pressure, medium pressure and soft pressure, and switch controls on and off.

Load/save mode

How to use load and save

The following loading and saving pages are local and U disk pages respectively.

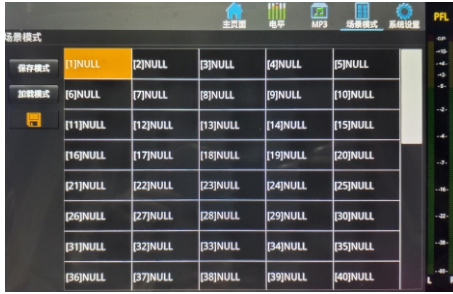

Local page

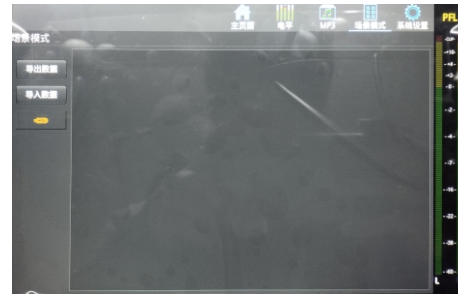

U disk page

In the process of digital station adjustment, the parameters are saved to the current mode in real time, and the mode used before the shutdown is the mode for each boot loading

How to save user data:

1. Set parameter data such as input, output and effect, and click the button to open scene mode at the top of the screen.
2. There are 100 users to save. Click the user you want to save, and then press the "Save Mode" button.

How to load user data:

1. Go to the Loading/Preservation page, select the user to be loaded, and then click the "Loading Mode" button.
3. There are 4 buttons in the MODE area of the control panel, where you can quickly call up the first 4 users of user data, and then press "OK" on the screen

Complete the call up of user data.

User's USB disk data:

- 1, set the input, output, effect and other parameters, to load and save the page, click the USB flash disk symbol in the lower left corner to enter the USB flash disk page (orange indicates there is a USB flash disk insert).
- 2, press the save key, write the name after the completion of the virtual keyboard ENTE (Enter key), and then press the confirm key can be saved to the U disk.
- 3, insert U disk will automatically identify. Load the user data from the U disk, and the display area is to select the current user data. After selecting, press the "Load" button, and then the user data can be loaded into the current channel.

Channel replication page



1. Set parameter data such as input, output and effect in the current input channel, and then click the channel at the bottom of the screen to copy.
2. Select the channel and click the Copy button to complete the COPY.

System Settings

Click the System button in the upper right corner of the main screen to enter the System Settings page

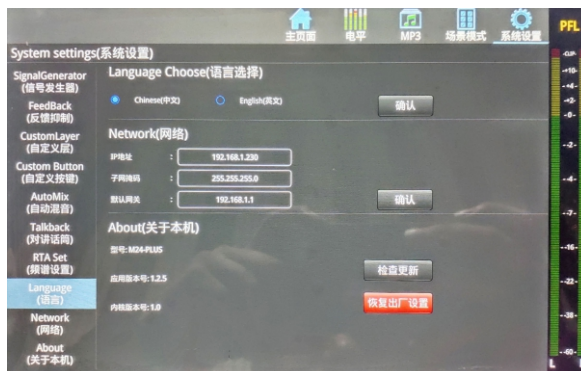

1. Network: You can change the network IP address here.
2. Language: Here to modify the language, the machine supports Chinese language and English language.
3. signal generator: is the pink noise, sine wave and white noise sent to the output channel signal, the size of the volume is controlled by the multi-function knob.
4. Feedback suppression: select the channel and feed back the current channel signal to this page for signal suppression.
5. Custom buttons: the eight free buttons on the upper right of the machine are customized as mode call/mute marshalling /DCA marshalling.
6. Custom layer: set the custom channel IN the custom layer, and then press the In-A/In-A button together to enable the function of the custom layer.
7. Automatic Mixing: Click to encode the channels that need to set up automatic mixing, and divide them into group X and group Y two groups.
8. Talk Back: Click to set any input or output as the intercom function to use.
9. RTA Spectrum Setting: Click to set the channel of spectrum function, spectrum PRE/POST mode and spectrum color setting.
10. restore factory Settings: the machine parameters to the factory Settings.
- 11, about the machine: here you can view the machine model, kernel version number, application version number, serial number of information.
12. Update: Software can be updated here.
Download the update software to the USB flash drive, then plug the USB flash drive into the mixer, click the button to open the update, it will automatically recognize that the software will automatically update, you need to wait.

Mp3/ sound card playback and recording

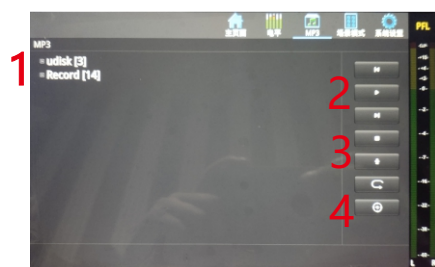

Play page

How to access the MP3 page:

1. Click the MP3 option at the top of the main screen to enter the MP3 page.
2. Plug in the U disk with the song, and the U disk will be automatically identified. So that the song is displayed.

Learn about MP3 pages:

1. The directory area can be swiped up and down to turn pages.
2. This area is Last, Pause/Play, Next, Random/Single Loop/Sequence.
- 3, start recording and pause recording, recording will automatically appear the name of the recording file, recording screen will display timing information
- 4, the total pause (can pause the playback or recording pause), song positioning, song deletion.

Note: MP3 and sound card playback options need to be switched in the digital channel

When recording, please set up the recording equipment in the main output page, if you need to choose MP3 recording, sound card on the selection of USB, the recording signal is the main output signal, so recording must ensure that the main output signal output is normal, otherwise it will not record the sound

DCA mute marshalling



Enter DCA marshalling - In the middle area of the I/O push layer, press the DCA button to enter the DCA silent marshalling page, and exit is the same.

At this point, the first eight pushers on the right of the push layer control eight DCA marshalling channels, and the channel guide screen also displays eight DCA marshalling information. You can select the corresponding INPUT and OUTPUT channels to marshal in DCA by clicking Input and Output below the main screen, and click Clear to clear the editing information.

(It should be noted that the corresponding input and output volume needs to be adjusted in advance before enrolling, so that the volume of the enrolling channel can be controlled by the DCA pusher with one key)

The volume of the DCA channel is controlled by the DCA marshalling button that you select.